

INSTALLATION / OPERATING INSTRUCTIONS

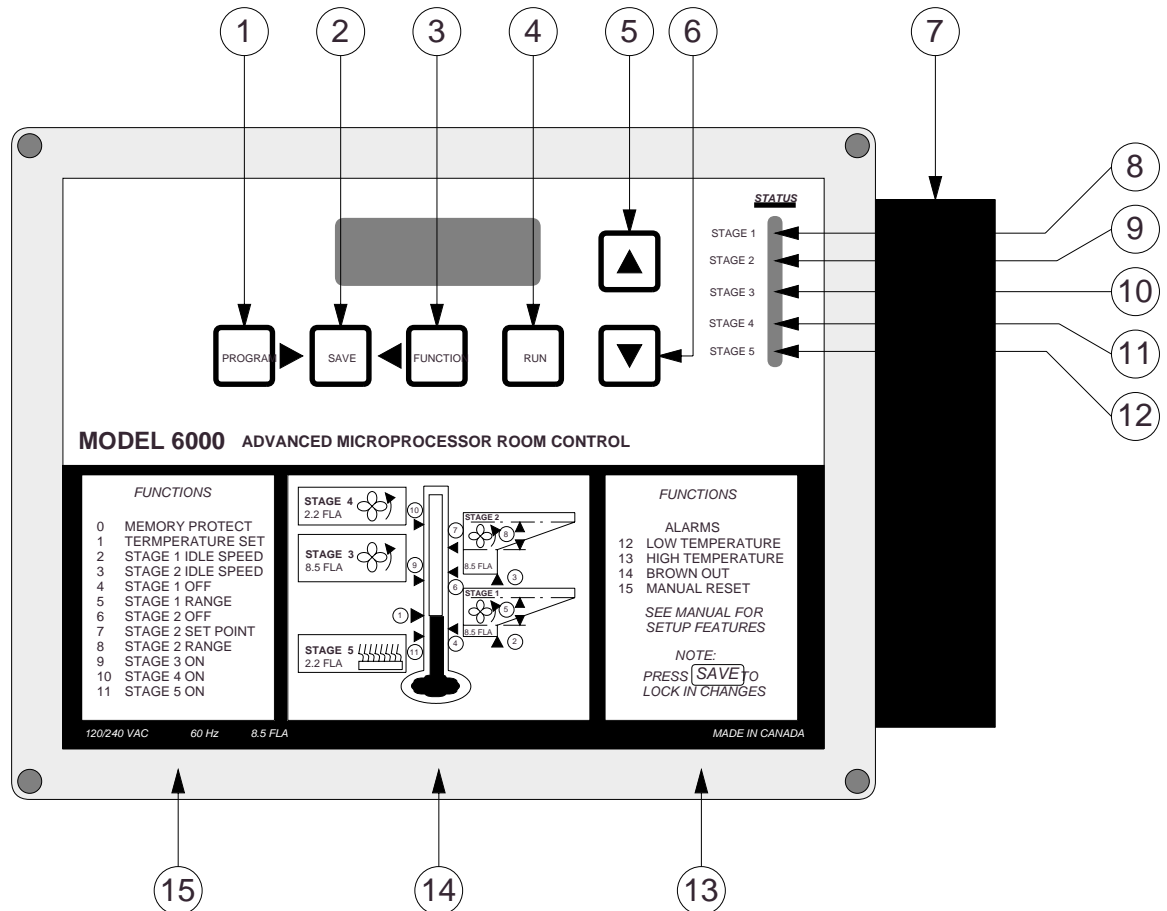

- (1) PROGRAM - Selects the desired operating program
- (2) SAVE - saves selected programs and function settings in memory
- (3) FUNCTION - scrolls through the function list
- (4) RUN - returns to normal operation, cancels alarms
- (5) INCREASE - adjusts function values
- (6) DECREASE - adjusts function values
- (7) HEAT SINK - keeps internal components cool
- (8) STAGE 1 - indicator light, on when Stage 1 is on
- (9) STAGE 2 - indicator light, on when Stage 2 is on
- (10) STAGE 3 - indicator light, on when Stage 3 is on
- (11) STAGE 4 - indicator light, on when Stage 4 is on
- (12) STAGE 5 - indicator light, on when Stage 5 is on
- (13) ALARM - list of Alarm functions
- (14) GRAPHICAL REPRESENTATION of function settings
- (15) FUNCTION LIST -list of program functions

Table of Contents

1. Introduction

1.1 Features of the Model 6000

2. Getting Started

2.1 Ventilation Plan

2.2 Equipment Requirements

2.3 Installing

3. Operating

3.1 Factory Programs

3.2 Customizing the Settings

4. Advanced Features

4.1 Setup Functions

4.2 Alarm Messages

4.3 Built-in Test Routine

4.4 Reloading the Factory Settings

4.5 Programming Shortcuts

5. Service, Maintenance, and Troubleshooting

5.1 Maintenance Tips

5.2 Parts Listing

APPENDIX A - Function Descriptions, Warranty Information

DEL-AIR
S Y S T E M S

Section 1 - Introduction

The Model 6000 (shown on the cover) is a microprocessor based ventilation control designed to centralize the control of an entire room. It operates two sets (stages) of variable speed fans, a combination of three stages of secondary fans and heaters, and an alarm system. Standard features of the Model 6000 include:

- Digital display of temperature, alarms, and settings,
- Seven factory set programs which can be easily changed,
- 115 or 230 VAC connectable with independent breakers for each stage if desired,
- Normally open or normally closed alarm contacts to signal high or low temperature, power interruptions, or low line voltage,
- Internal memory to retain settings during power failures, with auto-reboot,
- Two variable speed outputs rated at 8.5 full load amps each (with RFI noise suppressors),
- One full powered on/off output rated at 8.5 full load amps,
- Two Contactor outputs for signalling external power relays, each rated at 2.2 Amps,
- Three second full power start for variable speed outputs to minimize fan freeze-up,
- Compact design - 7" X 9" X 3.75" deep (180 X 230 X 95 mm),
- CSA approved, sealed plastic enclosure,
- Two year warranty,
- Sensor can be extended up to 1000 ft. or multiple sensors may be averaged.

Section 2 - Getting Started

This section will attempt to explain the purpose of the Model 6000, and will show you how to install the control.

2.1 Ventilation Plan

The Model 6000 is designed to control **all** the ventilation equipment within one room for **all** seasons. There are five control stages available. You should try to spread your equipment across these stages according to the rates required in different seasons. **DEL-AIR offers a free ventilation planning service to help you** stage your equipment properly with the Model 6000 (see or call your dealer).

All livestock raised in confinement have a similar heating / cooling demand curve (see Figure 1). In winter, a fairly constant low ventilation rate along with heat recovery or supplemental heat is needed to control humidity. As the weather warms up, ventilation needs rise exponentially. Maximum summer rates are often 15 to 20 times higher than the minimum winter rate! In some warm climates, spray cooling may be required to keep a comfortable environment for the animals when the ventilation equipment simply cannot cool the zone enough.

The Model 6000 can provide a smooth ventilation system which follows the "demand curve" throughout the year **automatically**. Figure 2 shows how the Model 6000 can be set up to do this using DEL-AIR ventilation products as an example. DEL-AIR dealers can provide general guidelines for equipment requirements. However, it is suggested that an Agricultural Engineer be contacted for exact ventilation requirements at each stage.

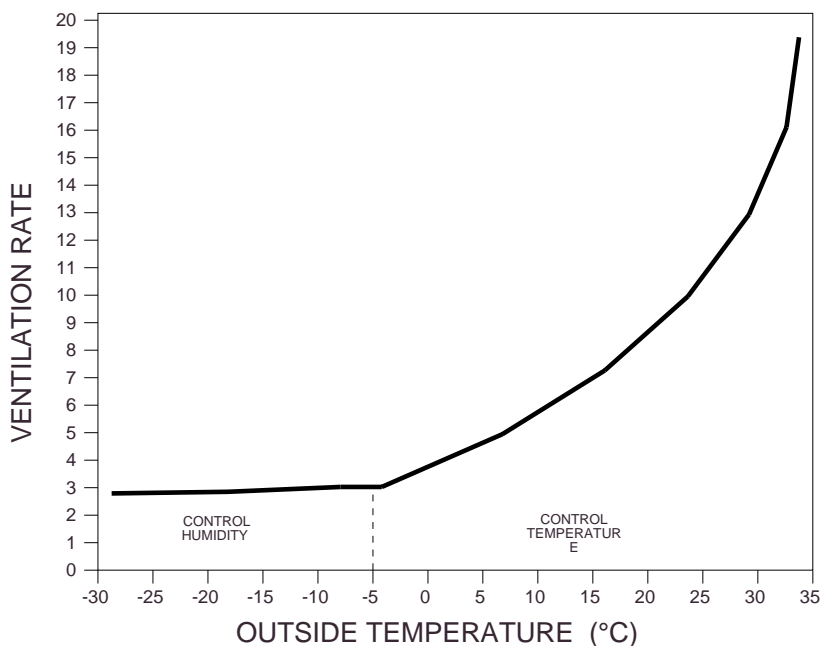

FIGURE 1 Typical livestock ventilation demand curve

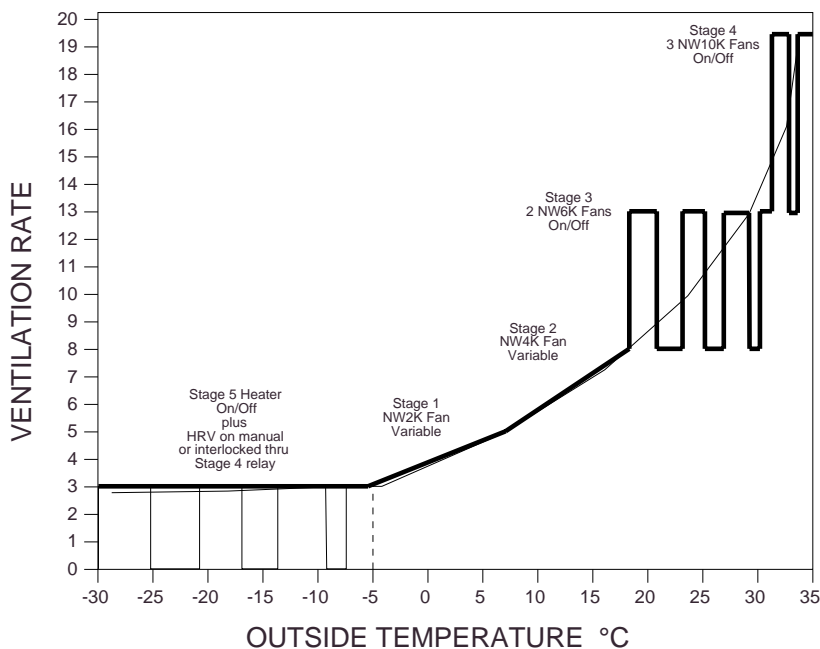

Figure 2 Staging fans and heaters with the Model 6000 to match the Ventilation Demand Curve

2.2 Equipment Requirements

Before you have finalized the size and placement of all fans and heaters you must check the current loads to ensure the electrical ratings of the Model 6000 are not exceeded. Relays or external power contactors should be used whenever the total load on any stage will exceed the rating of that stage. Your electrician should be involved in this step to decide on the best wiring approach. Figure 3 shows the current ratings of each stage of the Model 6000. All five stages plus the alarm contact and the Model 6000 circuit board itself may receive power from separate circuits. This enables you to balance the current load in your service panel and ensures ventilation in the event of a breaker trip-out.

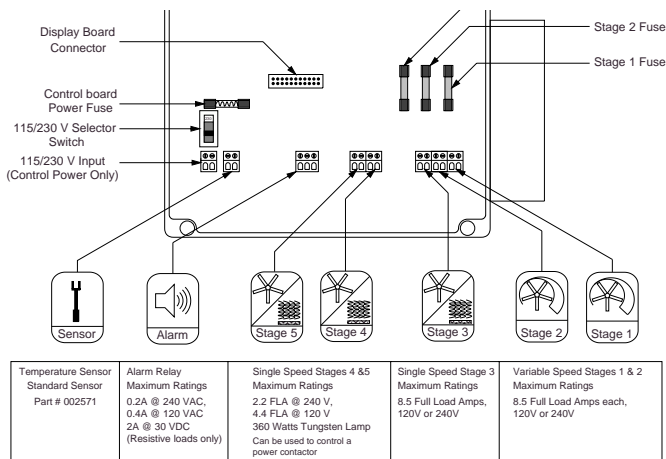

Figure 3 Electrical Ratings

Stages 1, 2, and 3 are each rated at 8.5 FLA. This means, for instance, you could connect up to ten DEL-AIR NW2K fans (@ 0.8 A each), or four DEL-AIR NW4K fans (@ 1.8 A each) to each of these stages. Stages 4 and 5 are light duty relays intended only for switching heavier power contactors. Your electrician must install these contactors separately from the Model 6000. Your DEL-AIR dealer can supply power contactors for 15 or 20 Amp fan loads. See the parts listing at the back of this manual.

The Alarm Contactor may be used for signalling a buzzer, siren, lights, or auto phone dialer, or may be integrated into any other alarm package. Contacts for normally open or normally closed are provided.

Power for all stages is independent from the power wired into the Model 6000. The terminals for connecting each stage do not supply power to the fan. They only "switch" the fan on or off. **Do not wire both power wires up to the contacts because when the contacts close you will cause a short circuit.** Wiring diagrams are shown in the installation section that follows.

2.3 Installation

Mount the Model 6000 in a convenient place in the room or adjacent hallway. Extend the temperature sensor to approximately the centre of the room at a height as low as practical. Ordinary unshielded 22ga bell wire may be used to extend the sensor leads up to 1000 ft. You may also purchase extended leads from your DEL-AIR dealer.

To avoid faulty readings, **sensor leads must stay 16" away from power wires.**

Multiple sensors can also be connected to the Model 6000 to read an average temperature from several points in the room. See your DEL-AIR dealer for details.

Follow the diagrams below to connect power to the Model 6000 and to connect the other equipment to the contacts in the control. Be sure to ground the control box and all loads. It is suggested that an electrician be called to ensure that the wiring is installed according to the applicable local electrical codes.

230 VAC Control Power

- Connect power to terminals 1 and 2 as shown in the diagram.
- Set the voltage selector switch to the 230 position
- A 1 Amp 250 V glass fuse is used to protect the circuit board from voltage spikes and surges

115 VAC Control Power

- Connect power to terminal 1 and neutral to terminal 2 as shown in the diagram.
- Set the voltage selector switch to the 115 position.

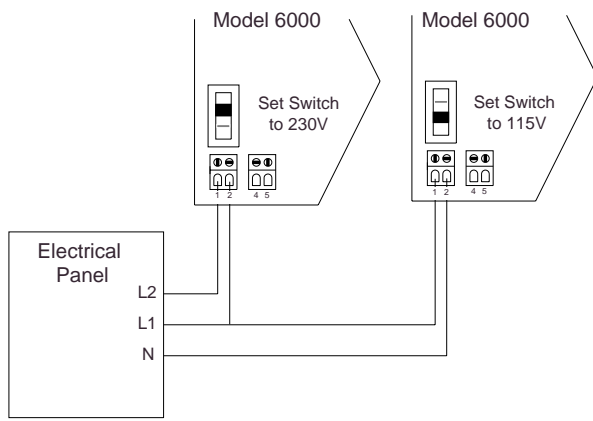

Care must be taken when wiring control to a three phase system

Stage 1 Variable Speed Fan

- Fans on Stage 1 should be connected to the same voltage as the control for proper variable speed operation. In other words, if the control is connected to 115 V, the Stage 1 fans should also be connected to 115 V. The same applies to 230 V (special rules apply for 208 V—Three Phase operation).
- Connect Stage 1 to terminals 34 and 35 as shown in the diagram. Remember: These terminals are only switches - no power is supplied from these terminals.

Temperature Sensor

- Connect sensor to terminals 4 and 5 as shown in the diagram.
- Sensor can be extended if desired. Use No. 22 AWG single pair wire (Bell wire), or order DEL-AIR part number 002576-XX (XX represents the length of sensor in feet) for an extended sensor. Polarity is not important; the sensor leads are reversible.
- When installing the extended sensor, do not run the cable next to other power cables. If you must cross over other other cables, ensure that the wires cross perpendicular to each other.

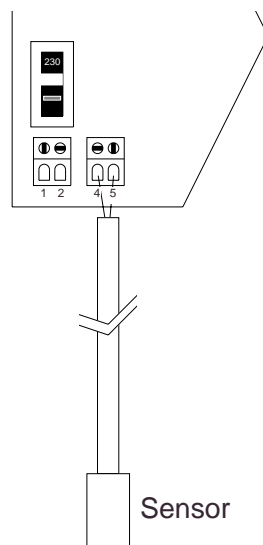

Stage 1 Variable Speed Fan

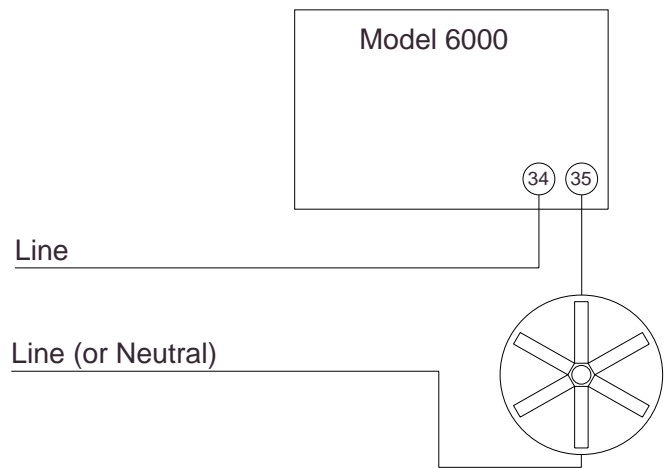

Stage 2 Variable Speed Fan

- Fans on Stage 2 should be connected to the same voltage as the control for proper variable speed operation. In other words, if the control is connected to 115 V, the Stage 2 fans should also be connected to 115 V. The same applies to 230 V (special rules apply for 208 V—Three Phase operation).
- Connect Stage 2 to terminals 32 and 33 as shown in the diagram. Remember: These terminals are only switches - no power is supplied from these terminals.

Stage 2 Variable Speed Fan

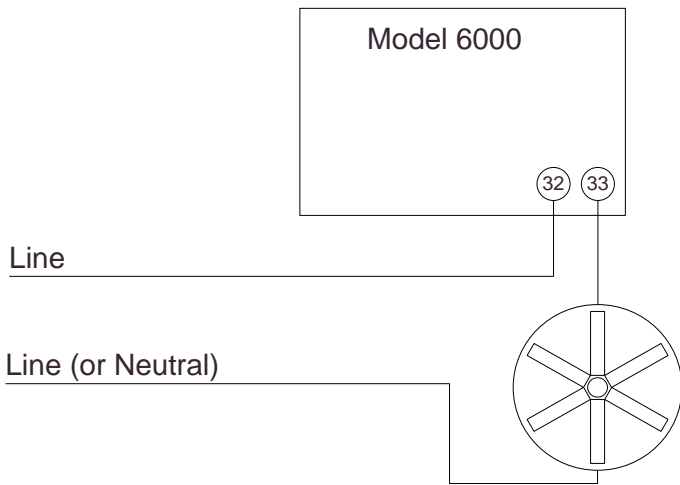

Stage 3 Single Speed Fan

- Stage 3 is designed to switch a large load and may not operate properly if the attached load is too small. To ensure proper operation, a minimum load of 0.3 Amps should be connected to this stage.
- Connect Stage 3 to terminals 30 & 31 as shown in the diagram. Remember: These terminals are only switches - no power is supplied from these terminals.
- You may operate Stage 3 at 115 V or 230 V regardless of the control's operating voltage.

Stage 3 Single Speed Fan

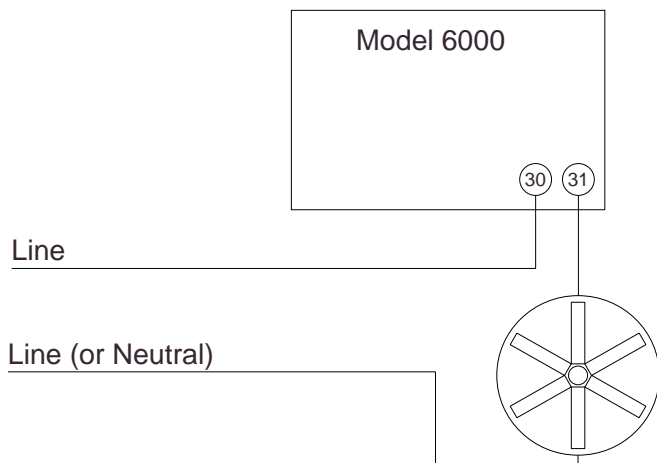

Stage 4 or 5 Contactor (Relay)

- A contactor (or relay) is required on these stages when the total load exceeds the rating of these stages. Furnaces with electronic or "hot surface" ignition will typically require the use of a contactor on this stage.
- Connect Stage 4 to terminals 24 and 25; connect Stage 5 to terminals 22 and 23.
- You may control 115 or 230 V loads on these stages regardless of the control's operating voltage.

Stage 4 or 5 Contactor

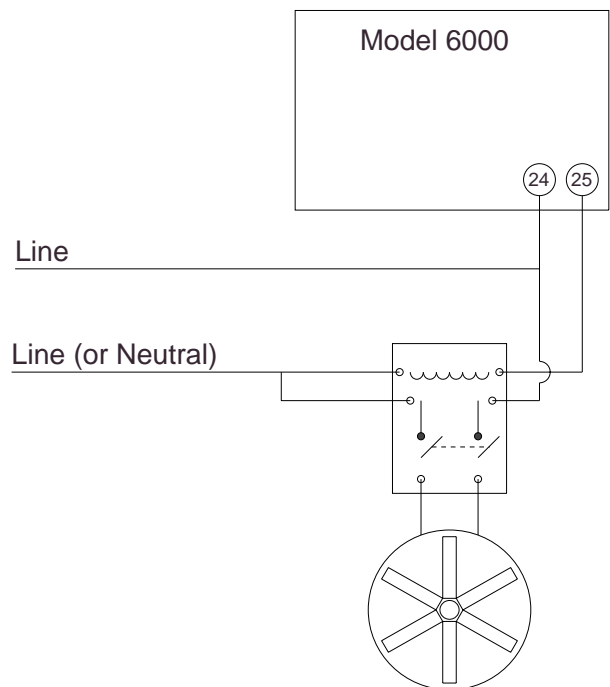

Stage 4 or 5 Heater

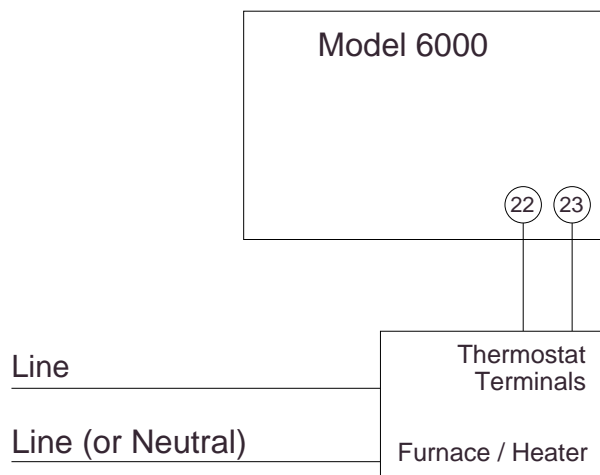

Stage 4 or 5 Furnace

- Furnaces with simple thermostat outputs may be switched directly from the Stage 4 or 5 contacts without the need for an external contactor. Refer to the wiring diagram.
- Stage 4 is set to "Cool" by default and must be configured to as "HEAT" in order to control a heater or furnace. Refer to Section 4 for information on how to change this configuration.

Three Phase Facilities

- The Model 6000 may be connected to 208 V Phase to Phase voltage - the voltage selector switch must be placed in the 230 position.
- Follow the diagrams to ensure that the fans are connected properly.

208V, Three Phase Wiring

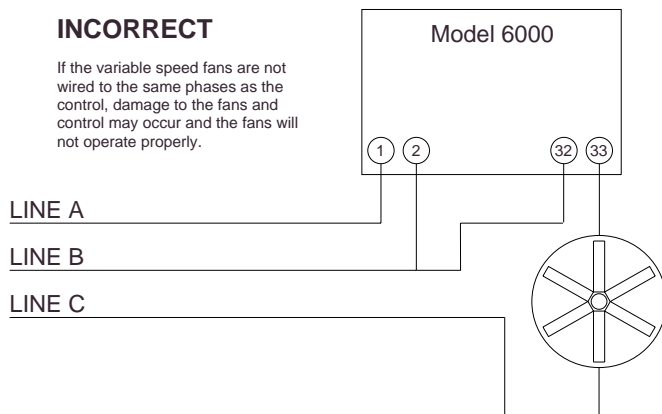
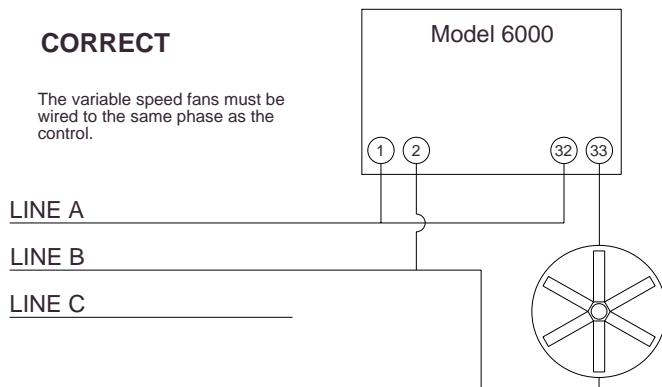

Section 3 - Operating

3.1 Factory Programs

DEL-AIR has provided Seven built-in factory programs to get you started. Table 1 shows the factory settings for each of the seven programs in both °C and °F. Select the program closest to your needs by pressing the PROGRAM button to scroll through programs A to g, then SAVE to lock in your selection.

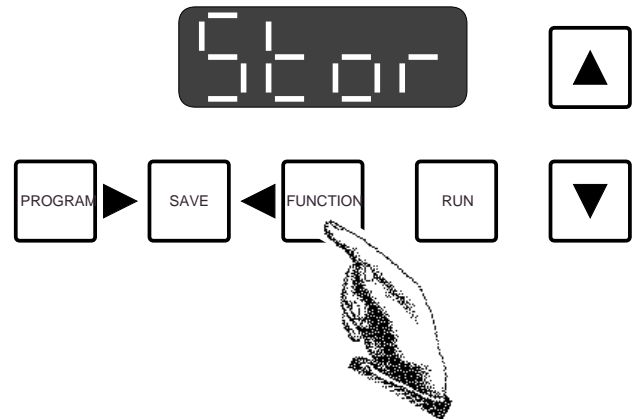
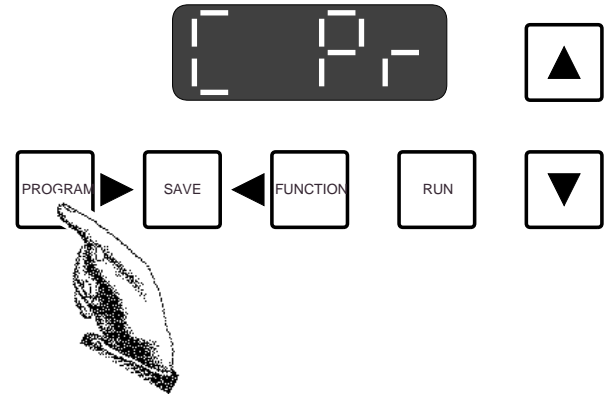

Assuming the wiring was done correctly, the ventilation equipment should now be working. Different fans and the heater may be operating depending on the actual temperature in the room. If the equipment does not seem to be functioning properly, there is a built in test routine that can be run to verify the wiring. See Section 4.3 for instructions on running the built-in test procedure.

The five factory programs are designed to get you going in a hurry. You can run your barn with these settings until you become familiar with the various customization features offered by the Model 6000.

3.2 Customizing the Settings

Follow the steps below to view and/or edit the functions in any program. After the functions have been edited they must always be **SAVED** to lock the changes into memory.

- 1) Press the PROGRAM button until the program that you want to edit is displayed. The display will flash the program letter (A to g) and Pr.
- 2) Press the Function button once. The first (left) digit shows the PROGRAM letter that is being edited. The second digit indicates if the program is operating (o) or not (blank). The digit on the right indicates the function Number. Function 0 is the memory protection.
- 3) Press DOWN to turn memory protect off. The display will flash Ao 0 and then oFF indicating memory protect has been turned off. The FUNCTIONS can now be adjusted. If memory protect is on, the functions can only be viewed. Attempting to adjust the FUNCTIONS while memory protect is on will result in an Err message.
- 4) Press the FUNCTION button to step through the function list until the desired function is reached. Refer to the label on the Model 6000 control or see Table 1 for a list of the functions.
- 5) Use the INCREASE/DECREASE buttons to adjust the setting. The FUNCTIONS can be adjusted to any value within the ranges found in Table 1.
- 6) Press SAVE to lock the changes in memory. The display will show Stor indicating the new setting has been stored in memory. If SAVE is not pressed before you go on, the function will revert back to the previous setting.

Follow the same procedure shown in steps 4 to 6 above for each function.

- 7) Press the RUN button to return to normal operation at any time. Pressing RUN will also cancel any errors or alarm messages which occur during normal operation.

If you do not press RUN, the control will revert back to normal operation after 1 minute of inactivity automatically.

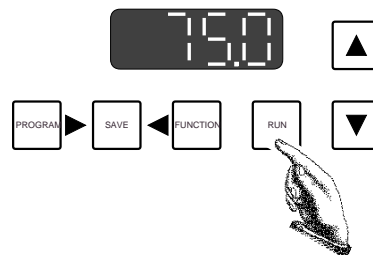
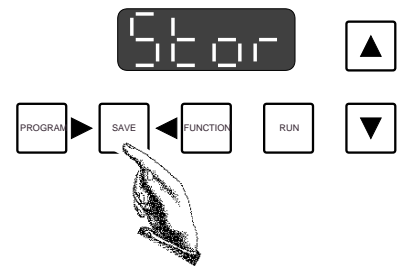
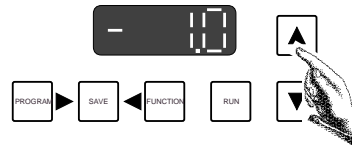
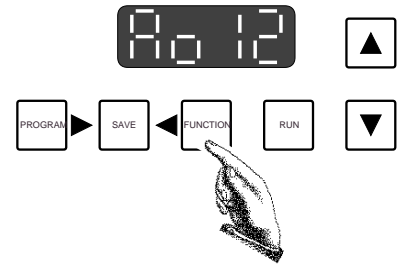
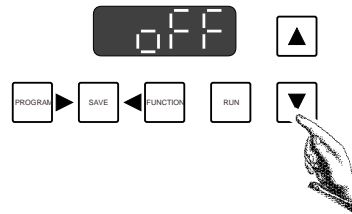
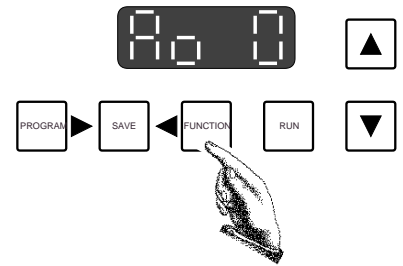
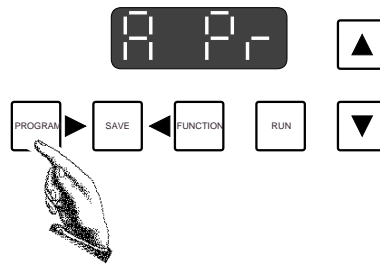

Section 4 - Advanced Features

4.1 Setup Functions

Setup (Hidden) Functions

The setup functions are to be programmed during initial installation. They generally do not need to be reprogrammed. The setup function affect all seven programs.

Editing the Setup Functions

Press the FUNCTION button once. Turn off the memory protection by pressing the DOWN arrow. Press the PROG and FUNCTION buttons simultaneously to access the setup functions. The setup functions can be adjusted as desired and stored the same way as the normal functions. After the setup functions have been changed and saved, press the RUN button to return to normal operation. The setup functions are listed in Table 2.

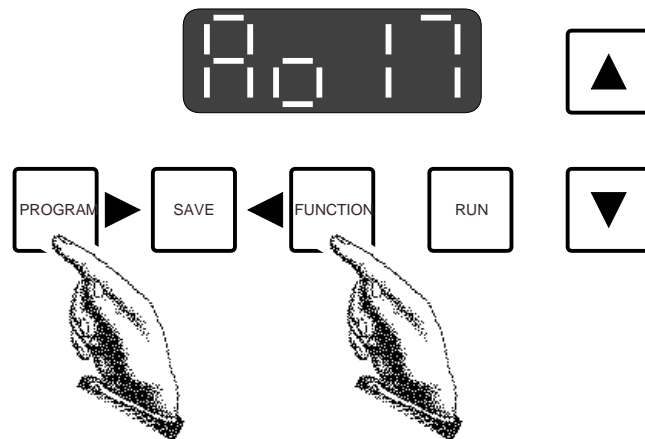









Refer to the Appendix for detailed information about each function.

Table 2 Setup Functions

Functions		Factory Setting	Adjustment Range	
No.	Description	A	Min	Max
17	Temperature Units	°F	°F	°C
18	Stage 3 Operation	Cool	Cool	Heat
19	Stage 4 Operation	Cool	Cool	Heat
20	Stage 5 Operation	Heat	Cool	Heat
21	Stage 1 Minimum Idle	20%	0%	99%
22	Stage 2 Minimum Idle	20%	0%	99%
23	Hysterisis (Dead Band)	0.5	0.5 °F (0.3 °C)	2.5 °F (1.4 °C)
24	Stage 1 P.F. Compensation	1.0	0.5	2.5
25	Stage 2 P.F. Compensation	1.0	0.5	2.5

4.2 Alarm Messages

Message	Problem	Solution
	Error - an incorrect key has been pressed	If LATCHING ALARMS (Function No. 15) is turned on, the Err message must be cleared by pressing the RUN button.
	Alarm High Temperature* - temperature is above the high temperature alarm setting (Function 13).	Check the fans to ensure they are operating properly. This alarm may occur on very hot days when the desired room temperature cannot be maintained.
	Alarm Low Temperature* - temperature is below the low temperature alarm setting (Function 12).	Check the heater to ensure it is operating properly. This alarm may also occur when a room is empty.
	Alarm Low Power* - the line voltage is low (i.e. a "brownout").	This may indicate a problem with the electrical service of the building. Check to be sure the 115/230 voltage selector switch is correct.
	Alarm Probe Disconnect* - the temperature sensor is disconnected.	The sensor or wire may be damaged or disconnected. NOTE: When a A Pd or a A PS alarm occurs, the heating and cooling stages will turn off and the variable stages will run at idle speed.
	Alarm Probe Short* - the temperature sensor is short circuited.	
	Alarm Power Failure* - the power has been interrupted.	Once power is restored, the control will operate properly and the alarm can be cleared by pressing the RUN button.
	Ventilation Off - Ventilation has been turned off in the program (Function 16).	When this is displayed, the variable speed stages and the cooling stages will be turned off. The heating stage(s) will operate normally.

* Press RUN to cancel any alarm message. Any of these on-screen messages will also trigger the alarm contacts and will activate any external alarms that are connected to the Model 6000.

4.3 Built-in Test Routine

The Model 6000 has a built-in test procedure. The test should be performed after the control has been installed and may be used at any time to check the operation of the control. The test procedure tests the circuitry in the control and each stage of equipment individually. Follow the instruction below to step through the test procedure.



If an alarm system is connected, be aware that it is normal for the alarm to be activated during most of the test procedure.

Starting the Test Routine

In order to start the test procedure, the power to the Model 6000 must be off. Turn on the power while holding the INCREASE and DECREASE buttons as illustrated. The Model 6000 will start up in the test mode.

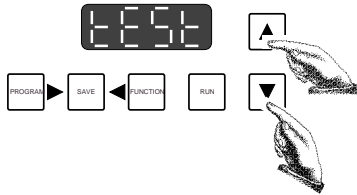

Sensor Test

Press the PROGRAM button once. The Model 6000 will display a number. If the sensor is OK, the number on the display should be between 100.0 and 125.0. If the number displayed is not in this range, check and replace the sensor if necessary.

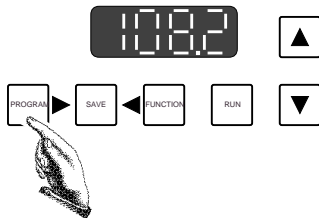

Press the PROGRAM button again. The Model 6000 will display the temperature. If the temperature displayed is not correct, make sure that the sensor is installed properly.

Memory Test

Press the SAVE button. The Model 6000 will display PASS if the factory programs

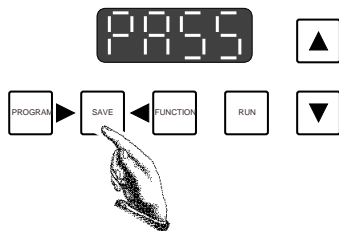

are in the memory. It will display FAIL if the programs have been changed in any way. This includes any changes you have made on purpose.

Display Test

Press the FUNCTION button to perform the display test. The Model 6000 will display 888 and then will count from 0 to 9 on each digit. After the display test is done, the Model 6000 will display "t dS" which stands for "test display."

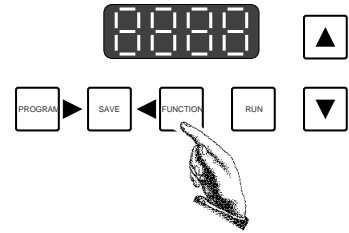

Variable Stage Test

Press the INCREASE (UP) button once. This will start the variable speed fan test. The display should be flashing tSP1 and oFF (tSP1 means "test variable speed stage 1"). Press the INCREASE button again. Now the display should flash tSP1 and FuLL and the Stage 1 fan should be running full speed. Press INCREASE again. The fan should be running at half speed and the display should flash tSP1 and HALF. Press INCREASE again and the fan will run at low speed. The display will flash tSP1 and Lo. NOTE: Some fans may not operate at the low speed programmed for test purposes. Pressing the INCREASE button four more times will cycle through the Stage 2 fan test. When the Stage 2 test is complete, pressing the INCREASE button again will restart the Stage 1 fan test.

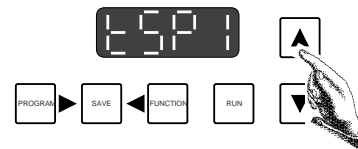

Relay Test

Press the DECREASE (DOWN) button to start the relay test. The display will flash t rl and ALAR (t rl stands for "test relay") and the alarm should be on. Press the DECREASE button again and the display will flash t rl and St 3. Now Stage 3 should be on and the alarm will be off. Press DECREASE again and

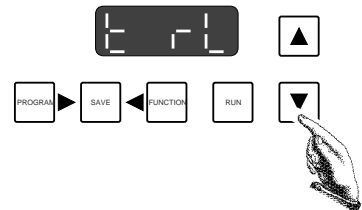

the display will flash t r l and St 4, and Stage 4 will turn on. Continue to press DECREASE to test Stage 5, then to test all three Stages together (Stages 3,4, & 5). Press DECREASE to start the relay test over again.

Reset Test

Press the RUN button. This will return the Model 6000 to normal operation. The display will flash t Sr one second and then reset (t SA stands for "test sanity circuit"). The display will be flashing the room temperature and may show a power failure alarm (A PF). Press the RUN button to clear the alarm. Other alarms might be displayed if the Model 6000 has not been programmed properly yet.

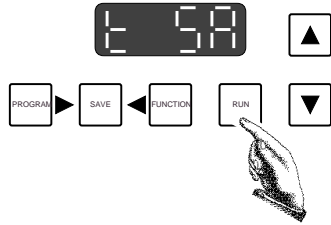

This completes the built-in test procedure in the Model 6000. If at any point during this test, the Model 6000 or equipment did not function properly, contact your DEL-AIR dealer or call 1-800-667-1722 (North American Toll Free).

4.4 Reloading the Factory Settings

The factory programs can be reloaded if so desired, to replace any changes you no longer want. If the changed programs are not operating properly or you wish to reset the original factory programs, follow the steps below.



When the factory programs are reloaded, all seven of the existing programs including the Setup Functions will be replaced. The Model 6000 will have to be configured again for the equipment that is

connected. Pay close attention to the configuration of Stages 3,4, and 5.

- 1) Turn off the power to the Model 6000.
- 2) Hold down the PROGRAM and

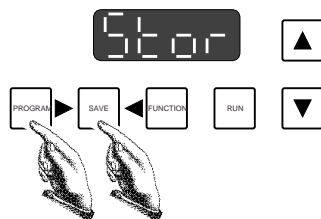

SAVE buttons.

- 3) While holding the buttons down, turn the power back on. The display will flash STOR for two seconds and then the Model 6000 will be in normal operating mode and will display the room temperature and any alarms which might be activated.
- 4) Refer to Section 4.1 to check and adjust the Setup functions to match your configuration.

4.5 Programming Shortcuts

Here are some tips to make programming easier and faster.

Scrolling Backwards

When viewing or editing the functions, sometimes it is helpful to scroll backwards through the Function list. To do this, press the function and increase buttons simultaneously. Instead of displaying the next Function on the list, the Model 6000 will display the previous Function.

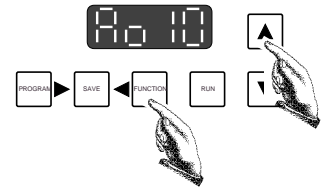

Faster Changes

When editing the setting of a Function by adjusting it up or down, hold down either button and press the other one. This will change the setting ten times faster. For example, if you want to INCREASE the setting, hold down the INCREASE (UP) button and then press the DECREASE (DOWN) button. The setting will increase ten times faster. To decrease the setting ten times faster, hold down the DECREASE button and then press the INCREASE button.

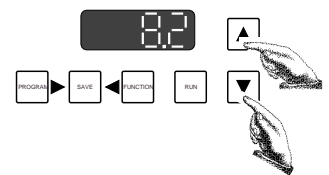

Section 5 - Servicing and Maintenance

APPENDIX A

FUNCTION DESCRIPTIONS

5.1 Maintenance Tips

Most electronic controls will last a long time if they are installed correctly and are maintained properly. The Model 6000 has been carefully designed to be able to operate in the harsh environment of a livestock barn. However, like most other electrical equipment, it requires special care in order to avoid expensive damage. Follow the steps below to avoid damage and keep your control operational:

- 1) After the first two weeks of operation, remove the cover from the unit and check for moisture inside. Be sure to turn off the power to the control before opening the cover.
- 2) If moisture is present, wipe it out with a dry cloth and check the cable entry points and rubber gasket for proper sealing.
- 3) If the cable connectors are not sealing, apply silicon sealant around the cable.
- 4) Check the control again after two weeks to verify that it is properly sealed.
- 5) Once per year, open and inspect the control for moisture and repeat the steps above to keep moisture from reappearing.

5.1 Parts Listing

Should additional equipment be required or if you require any repairs to your control, the following table lists the part numbers. Please consult your DEL-AIR Dealer or the person you purchased the control from. Refer to the LIMITED WARRANTY CONDITIONS which appear on the last page for warranty information.

Part No.	Description
002571	Sensor Probe with 6' lead
002576	Extended Probe (specify length in feet)
002560	Ceramic Fuse 2 CABC, 12 Amp
500500	Replacement Model 6000 (Warranty)

Main Parameters

- 0 **MEMORY PROTECT (ON/OFF)** - ensures functions are not changed by accident. Memory protect must be turned off every time a function is edited. The memory protect function can not be stored and is turned on automatically when the control is returned to normal operation.
- 1 **TEMPERATURE SET (Start P-Band 1) (32.0 - 110.0°F, 0.0 - 43.3°C)** - is the target room temperature. All differentials and alarms are referenced to this Temp. Set. It is the turn on point of the Stage 1 variable speed fan and the starting point of the stage 1 P-Band (Function #5).
- 2 **STAGE 1 MINIMUM VENTILATION (Minimum Idle (#21)-99)** - is the idle speed in % of full power at which the Stage 1 fan will idle. It cannot be adjusted below the setting of the Minimum Idle (#21) function.
- 3 **STAGE 2 MINIMUM VENTILATION (Minimum Idle (#22)-99)** - is the idle speed in % of full power at which the Stage 2 fan will idle at. It cannot be adjusted below the setting of the Minimum Idle (#22) function.

Differentials

- 4 **STAGE 1 OFF (IDLE, -20.0 to 0.0°F, -11.0 to 0.0°C)** - the number of degrees below Temp. Set at which the Stage 1 fan turns off. For example, if Temp. Set (#1), is set to 80°F and Stage 1 Off (#4), is set at 8°F the fan will idle when the temperature is between 80°F and 72°F, and will be off below 72°F. Idle means the fan will continue to idle at all temperatures below the Temp. Set.
- 5 **STAGE 1 RANGE (0.0 to 16.0°F, 0.0 to 8.9°C)** - the range is the number of degrees above Temp. Set before the Stage 1 fan reaches full speed. For example, if Temp. Set (#1), is set to 80°F and Stage 1 Range (#5), is set at 5°F the variable speed fan will speed up from idle to 100% between 80°F and 85°F.
- 6 **STAGE 2 OFF (IDLE, -20.0 to 0.0°F, -11.0 to 0.0°C)** - the number of degrees below the Stage 2 Temp. Set at which the Stage 2 fan turns off. For

example, if Temp. Set (#1), is set to 80°F, Stage 2 set point (#7) is set to 10°F, and Stage 2 Off (#6), is set at 3°F the stage 2 fan will idle when the temperature is between 90°F and 87°F, and will be off below 87°F.

- 7 STAGE 2 SET POINT** (-10.0 to 15.0°F, -5.5 to 8.4°C, OFF) - is the turn on point for the Stage 2 variable speed fan. All Stage 2 differentials are with respect to this setting. For example, if the Temp. Set (#1), is 80°F and Stage 2 Set Point (#6), is set to 10°F, the Stage 2 fan will turn on at 90°F,
- 8 STAGE 2 RANGE** (0.0 to 16.0°F, 0.0 to 8.9°C) - the range is the number of degrees above Stage 2 Temp. Set before the Stage 2 fan reaches full speed. If Temp Set (#1) is set to 80°F, Stage 2 Set Point (#7), is set to 10°F and Stage 2 Range (#8), is set at 5°F, the Stage 2 variable speed fan will start to increase speed at 90°F and will be at full speed at 95°F.
- 9 STAGE 3 ON** (-10.0 to 15.0°F, -5.5 to 8.4°C, OFF) - the number of degrees above or below the Temp Set at which Stage 3 will turn on. If the Temp. Set (#1), is set to 80°F and Stage 3 On (#9), is set to 5°F, Stage 3 will turn on at 85°F. Stage 3 is factory set up for cooling fans. To change to heat, see #18.
- 10 STAGE 4 ON** (-10.0 to 15.0°F, -5.5 to 8.4°C, OFF) - the number of degrees above or below the Temp. Set at which Stage 4 will turn on. If the Temp. Set (#1), is set to 80°F and Stage 4 On (#10), is set to 10°F, Stage 4 will turn on at 90°F. Stage 4 is factory set up for cooling fans. To change to heat, see #19.
- 11 STAGE 5 ON** (-10.0 to 15.0°F, -5.5 to 8.4°C, OFF) - the number of degrees above or below the Temp. Set at which Stage 5 will turn on. If the Temp Set (#1), is set to 80°F and Stage 5 On (#11), is set to -5°F, Stage 5 will turn on at 75°F. Stage 5 is factory set up for heat. To change to Cool, see #20.
- 12 LOW TEMPERATURE ALARM** (OFF, -35.0 to 0.0°F, -19.4 to 0.0°C) - the number of degrees below the Temp Set that a low temperature alarm will be triggered, (A Lt). This alarm may be disabled by adjusting it to OFF.
- 13 HIGH TEMPERATURE ALARM** (0.0 to 35.0°F, 0.0 to 19.4°C) - the number of degrees above the Temp Set that a high temperature alarm will be triggered, (A Ht). This alarm may be disabled by adjusting it to OFF.

The following functions are common to all programs. When they are changed in one program, they change in all of the programs.

- 14 BROWN OUT** (Low Power) ALARM (ON or OFF) - when the line voltage drops below the proper operating level, a brown out or low power alarm will be displayed (A LP). This alarm may be disabled by adjusting it to OFF.
- 15 MANUAL RESET** (ON or OFF) - when this function is turned ON, all alarms will be displayed on the Model 6000 and will keep flashing after the alarm condition is gone, until they are reset by pressing the RUN button. If this function is turned OFF, the display will automatically clear when the condition returns to normal.
- 16 VENTILATION** (ON - OFF) - when this function is turned OFF, the variable speed outputs and cooling stages are turned off completely. The heating stages are not affected. Ventilation may be turned OFF when a room is vacant to conserve energy. When it is turned OFF the Model 6000 will display VoFF. **DO NOT** use this to shut down fans to work on the wiring. Ensure the breakers are turned off.

Hidden Setup Functions

The Setup Functions are common to all programs. When they are changed in one, they effect all other programs. See 4.1 to edit setup functions.

- 17 TEMPERATURE UNITS** (°F or °C) - selects the temperature units. Select °F or °C to choose the units for all displays and programming.
- 18 STAGE 3 OPERATION** (Heat or Cool) - this function programs the Stage 3 output to operate as a heating stage or a cooling stage. When it is set to HEAT, the stage turns on below the Stage 3 On (#9). If it is set to COOL, the stage turns on above the Stage 3 On (#9).
- 19 STAGE 4 OPERATION** (HEAT or COOL) - this function programs the Stage 4 output to operate as a heating stage or a cooling stage. When it is set to HEAT, the stage turns on below the Stage 4 ON (#10). If it is set to COOL, the stage turns on above the Stage 4 On (#10).

- 20 STAGE 5 OPERATION** (Heat or Cool) - this function programs the Stage 5 output to operate as a heating stage or a cooling stage. When it is set to HEAT, the stage turns on below the Stage 5 on (#11). If it is set to COOL, the stage turns on above the Stage 5 On (#11).
- 21 STAGE 1 MINIMUM IDLE** (0 to 99) - this function limits the range of idle settings to only those which the fan will operate. If it is programmed to 20 the Stage 1 Min. Vent (#2) function cannot be adjusted below 20. It is recommended that this function be programmed to correspond to the lowest speed at which the motor can still operate.
- 22 STAGE 2 MINIMUM IDLE** (0 to 99) - same as #21.
- 23 HYSTERESIS** (0.5 to 2.5°F, 0.3 to 1.4°C) - this is the number of degrees of difference between the turn-on point and turn-off point for all stages (Deadband). It is often used to prevent rapid cycling if a heater or fan is oversized for the room.
- 24 STAGE 1 POWER FACTOR COMPENSATION** (0.5 to 2.5) - this is set at the factory to 1.0 and should only be adjusted if the Stage 1 variable speed fan does not operate properly with the Model 6000. Consult Del-Air before adjusting this number.
- 25 STAGE 2 POWER FACTOR COMPENSATION** (0.5 to 2.5) - this is set at the factory to 1.0 and should only be adjusted if the Stage 2 variable speed fan does not operate properly with the Model 6000. Consult Del-Air before adjusting this number.

Del-Air Systems Ltd.
1704 - 4th Avenue
P.O. Box 2500
HUMBOLDT, Sask.
S0K 2A0

PHONE: (306) 682 - 5011

FAX: (306) 682 - 5559

TOLL FREE (U.S.A.): 1-800-667-1722

Printed in Canada
(Inspected TLJ -05/96)

LIMITED WARRANTY

DEL-AIR Systems Ltd. warrants this unit, subject to the following terms and conditions. This warranty is valid to the original purchaser only for a period of 2 years from the date of Manufacturing. Manufacturing date is stated in the first six digits of serial number in the form year-month-day. DEL-AIR Systems Ltd., hereby warrants that should this product prove defective by reason of improper workmanship, DEL-AIR Systems Ltd. will repair the unit, providing all necessary parts replacements without charge for either parts of labour.

CONDITIONS

1. Installation must be made in accordance with the enclosed installation instructions-including the use of liquid-tight connectors for all wiring connections to the unit.
2. The unit must not have been previously altered, modified or repaired by anyone other than DEL-AIR Systems Ltd.
3. The unit must not have been subject to accident, misuse, abuse or operated or installed contrary to the instruction contained in the accompanying manual. The opinion of DEL-AIR Systems Ltd. with respect to these matters shall be final.
4. The person requesting the services provided hereunder must be the original purchaser of the unit and furnish proof thereof at the time of such request.
5. This warranty is applicable only to DEL-AIR Systems Ltd. Model 6000.
6. All transportation charges on units submitted for warranty repair must be borne by the purchaser.
7. For warranty services return unit together with original proof of purchase to your dealer.

EXCEPT TO THE EXTENT PROHIBITED BY APPLICABLE LAW, NO OTHER WARRANTIES, WHETHER EXPRESSED OR IMPLIED, INCLUDING WARRANTIES OF MERCHANTABILITY AND FITNESS FOR A PARTICULAR PURPOSE, SHALL APPLY TO THIS UNIT. ANY AND ALL IMPLIED WARRANTIES ARE EXCLUDED. DEL-AIR SYSTEMS LTD. SHALL NOT BE LIABLE FOR CONSEQUENTIAL DAMAGES SUSTAINED IN CONNECTION WITH THE SAID UNIT. DEL-AIR SYSTEMS LTD. NEITHER ASSUMES NOR AUTHORIZES ANY REPRESENTATIVE OR OTHER PERSON TO ASSUME FOR IT ANY OBLIGATION OR LIABILITY OTHER THAN SUCH AS IS EXPRESSLY SET FORTH HEREIN.

DEL-AIR Systems Ltd. reserves the right to improve or alter the Model 6000 without notice.